

**DEEP FOUNDATIONS INSTITUTE  
30th ANNUAL CONFERENCE  
ON DEEP FOUNDATIONS**



**DEEP FOUNDATIONS INSTITUTE  
CONFERENCE PROCEEDINGS**

**2005**

**September 22 - 24, 2005  
Chicago, Illinois**

## **Helical Piers with Grouted Shafts – A Case History**

Shawn Downey, Michael M. Blendy, and Frank D'Angelo, Jr.

## HELICAL PILES WITH GROUTED SHAFTS – A CASE HISTORY

Shawn Downey, CHANCE Civil Construction/Hubbell Power Systems, Centralia, Missouri, USA  
Michael M. Blendy, Michael M. Blendy P.E. Corp, Ramsey, New Jersey, USA  
Frank D'Angelo, Jr., D'Angelo Brothers, Inc., Philadelphia, Pennsylvania, USA

---

### Abstract

A grouted helical pile was used to support new buildings in the reconstruction of a large residential development. Foundation options were complicated by urban fill underlain with variable alluvial soil. A driven timber pile and grade beam system was recommended to support the new buildings. Other foundation options are also discussed. The grouted helical pile was quoted as an alternate and ultimately won the bid based on the economics and performance of the system. Data from 8 load tests was used to develop an empirical site specific relationship for determining pile capacity based on both installing torque and installation depth. Design to incorporate tolerance on installed pile location is presented. With three phases completed, 3645 grouted helical piles had been installed to support 554 residential units spread across 18 city blocks on the 44 acre site.



### Introduction

The Philadelphia Housing Authority reconstructed the Tasker Homes housing complex located in southern Philadelphia, Pennsylvania, adjacent to the Schuylkill Expressway in the Grays Ferry area. Keating Building Corp. and Pennoni Associates were the general contractor and structural engineer respectively. The original Tasker Homes development was constructed from 1940 to 1941 and consisted of 44 acres of primarily two and three-story residential brick buildings. These buildings were supported by a timber pile foundation system due to heterogeneous urban fill. The structural condition of the buildings supported on the timber piles was generally good in comparison to

areas outside the buildings which had settled possibly up to 2-feet in places.

The reconstruction was split into three phases seen in Figure 1 – Site Plan. The existing buildings were demolished and the resulting rubble sorted to remove unsuitable material. The remaining suitable material, brick and concrete rubble, asphalt, mortar, gravel, sand and rock, was used as fill on top of the existing urban fill. Material larger than 8-inches was crushed. Foundations for the new structures had to bear on native soil below the urban fill to ensure adequate support.



Figure 1 – Site Plan

Geology

The site is located within the Atlantic Coastal Plain Physiographic Province. According to geological maps of the area, the site is underlain by the Pleistocene age Trenton Gravel Formation. The Trenton Gravel Formation is characterized by a thin layer of gray to pale reddish-brown, very gravelly sand interstratified with cross-bedded sand and clayey silt beds. The Trenton Gravel Formation is underlain by unconsolidated sediments of the Tertiary Pennsauken and Bridgeton Formations. These formations are characterized by dark-reddish-brown cross-stratified feldsparic quartz sand. Thin beds of fine gravel are common with rare layers of clay or silt. The Wissahickon Schist Formation underlies these formations.

Subsurface Conditions

Powell-Harpstead, Inc. provided the Geotechnical Engineering Evaluation [Harpstead, Morrison (2002)]. Test borings were drilled with a truck-mounted drill rig using hollow-stem auger drilling techniques. Samples were obtained using the Standard Penetration Test defined by ASTM D-1586 utilizing a two-inch OD split barrel sampler driven at least 18-inches by a 140 lb

hammer dropping 30-inches. 70 test borings were performed on Phase I alone with additional borings for Phase II & III. After the test borings were completed, the site was stripped of vegetation, topsoil, trees and tree roots larger than one-inch. The first layer of soil was one to four-feet thick of fill that had been generated from the demolition of the original buildings including brick, asphalt, concrete rubble, sand and gravel. This fill layer was underlain by urban fill two to 24-feet thick, but generally less than 14-feet thick. This urban fill was highly variable in composition and typically consisted of dark brown to black silty fine sand to sandy silt with various amounts of ash, brick fragments, gravel, clay and even isolated areas of household trash. Apparently, part of Phase I had been used as a dump site. The fill layers were underlain by alluvial soil in all test borings. Throughout the site, 4 main alluvial sites were encountered: silt, ranging from medium to very hard, with various amounts of sand and clay; fine sand, ranging from very loose to very compact, with various amounts of silt and clay; fine to coarse sand, ranging from medium compact to very compact, with various amounts of clay, silt and gravel; and clay, ranging from soft to very hard, with various amounts of silt and sand.

The water table depth varied across the site from 22 to 30-feet below the ground surface.

**Foundation Options**

The foundation options were complicated by both the depth and heterogeneous nature of the fill. In addition, the urban fill was classified as regulated resulting in high disposal fees at a landfill.

Conventional strip and spread footing would have had to be founded on properly compacted select load-bearing fill or competent native alluvial soils. This would have required over-excavation and backfill. Disposal cost of the regulated fill made this cost prohibitive. Similarly, drilled shafts were not economical due to the disposal cost for the spoils.

Based on site conditions, timber piles 20 to 30-feet long with a 20 ton design load were recommended for support of all new structures, steps and utilities for the project. The grouted helical pile was quoted as an alternate deep foundation, see Figure 2. This system could provide working loads of 40 ton in the same 20 to 30-foot depth as the driven timber pile with the advantage that it could be easily extended to a deeper depth if required. Vibration free installation and minimal mobilization-demobilization costs were other advantages. The grout column also protected the steel shaft in the potentially corrosive urban fill. Consequently, the grouted helical pile was incorporated into the project design.

**Grouted Helical Pile**

A helical pile is a segmented deep foundation system. There is a central steel shaft to which helical plates are welded. These helical bearing plates enable the pile system to be literally screwed into the soil when torque is applied to the shaft. In this case, the central shaft was 1-3/4 inches square. The first section or Lead Section contained the helical bearing plates. Figure 3 is a

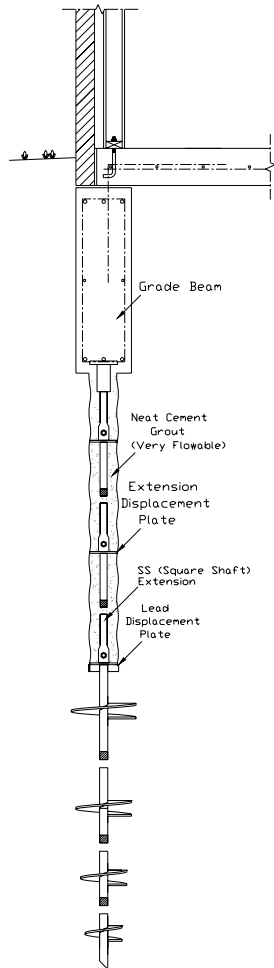

Figure 2  
Grouted Helical Pile

drawing of the Phase I Lead Section consisting of 8, 10, 12 and 14-inch diameter helical plates and an Extension. For Phases II and III, the Lead Section was changed to a 6, 8, 10 and 12-inch helical configuration. This

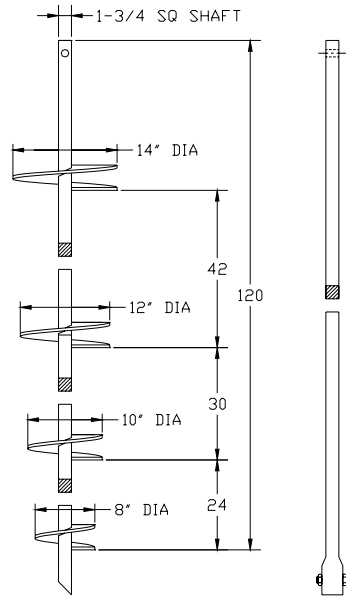

Figure 3  
Lead Section and Extension

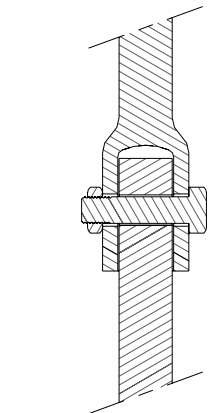

Figure 4  
Forged Coupling

Lead Section penetrated the urban fill more easily. Extensions, also 1-3/4 inches square, were bolted to the previous section in 5, 7 and 10-foot lengths until the helices penetrated the bearing strata. Forged couplings, Figure 4, are an integral part of the Extension and allow the sections to be bolted together in the field. Each component is hot dip galvanized for additional corrosion protection.

Surrounding the helical pile with a grout column simply requires a few extra components, see Figure 2. A soil clearing device called a Lead Displacement Plate is installed with the Lead Section. This Lead Displacement Plate displaces and compacts the soil as the helical pile rotates and advances into the soil leaving a void around the shaft. This void is immediately filled with a flowable grout that flows under the force of gravity. The grout used was a neat cement grout meeting ASTM 150 Type 1 Portland Cement. This system simply compacts the soil to create the void around the shaft and does not generate spoils at the surface. As Extensions were added, an Extension Displacement Plates was used to centralize the steel shaft in the grout column.

**Determining Capacity**

Due to the variability of both the urban fill and the underlying alluvial soil, an empirical method was developed to determine the axial capacity of the helical pile system.

The capacity of a grouted helical pile has two components. First, end-bearing or base resistance is developed on the helical bearing plates. The bearing

plates are spaced along the shaft at distances far enough apart that the plates act as individual bearing elements. This end-bearing capacity is proportional to the applied installation torque. An empirical factor or ratio for bearing capacity to installation torque can be determined through testing on a site specific bases. The second component of the capacity is side resistance or friction developed along the grouted shaft at the grout-soil interface.

Figure 5 illustrates development of both side and base resistance [Reese, Wright (1977)]. Maximum side resistance (friction) is mobilized after downward displacement of from 0.5 to greater than 3 percent of the shaft (grout column) diameter, with a mean of approximately 2 percent [Reese, Wright (1977)]. This side resistance continues almost equal to the ultimate value during further settlement. No significant difference is found between cohesive and cohesionless soil except that further strain in clay sometimes results in a decrease in shaft resistance to a residual value. In contrast, the point (helix) resistance develops slowly with increasing load and does not reach a maximum until settlements have reached on the order of 10 percent of the diameter of the base (largest helix) [Terzaghi, Peck (1948)].

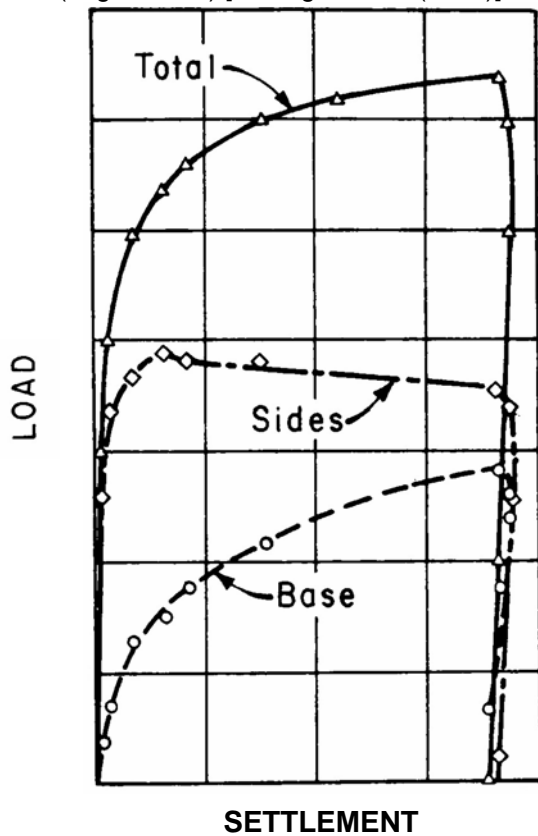

Figure 5  
Load-Settlement Curves, Reese, Wright (1977)

To provide a conservative approach, the capacity was determined by the load that caused a net settlement (total settlement minus the elastic compression) equal to 8 percent of the largest helix. For the 8, 10, 12 & 14 helix configuration,  $14 \times 0.08 = 1.12$ -inches plus the elastic compression,  $PL/AE$ .

A series of 8 compression test were conducted across the site. The soil borings were used to select test locations that provided a variety of soil conditions. Full scale compression test were conducted meeting the ASTM D1143, Quick Load Test Method for Individual Piles, standard.

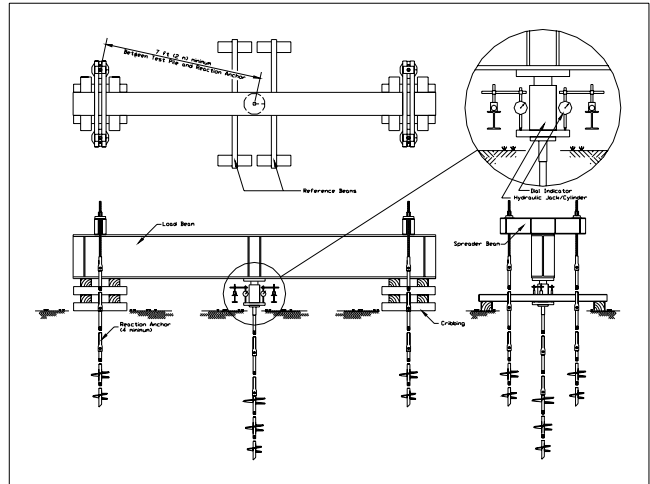

Figure 6 – Performance Test Apparatus

A 150 ton hydraulic jack applied the compression load while a steel I-beam provided the reaction to the load, see Figure 6. Helical tension anchors provided the uplift resistance to secure the beam. Two dial-indicators mounted on independent reference beams measured deflection. The load was applied in roughly 20,000 lb increments with a constant time interval of 2-1/2 minutes between increments. The load was generally reduced in 4 approximately equal decrements. Figure 7 was the performance test graph

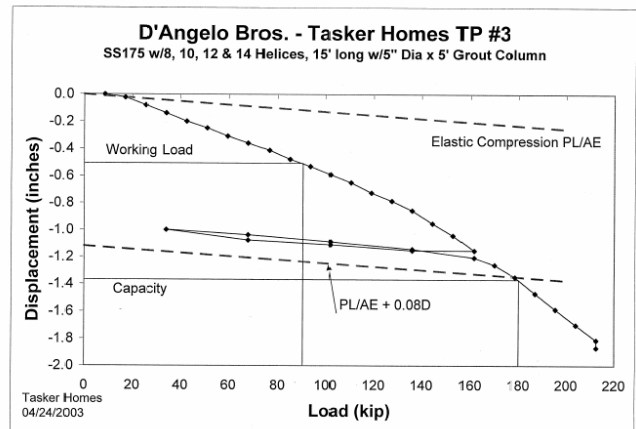

Figure 7 - Load-Settlement Curve for Test Pile #3

## Load Test Summary

Test No	Square Shaft Size inches (mm)	Helix Configuration inches (mm)	Total Length feet (m)	Installing Torque ft-lb (kN-m)	Ultimate Capacity kip (kN)	Working Load kip (kN)	Deflection at Working Load inches (mm)
1	1-3/4 (44.5)	8, 10, 12 & 14 (203, 254, 305 & 356)	16 (4.9)	10,000 (13,600)	170* (756)*	85 (378)	0.40 (10.2)
2	1-1/2 (38.1)	8, 10 & 12 (203, 254 & 305)	16 (4.9)	7,000 (9,500)	150 (667)	75 (334)	0.40 (10.2)
3	1-3/4 (44.5)	8, 10, 12 & 14 (203, 254, 305 & 356)	15 (4.6)	10,000 (13,600)	180 (801)	90 (400)	0.50 (12.7)
4	1-3/4 (44.5)	8, 10, 12 & 14 (203, 254, 305 & 356)	32 (9.8)	3,000 (4,100)	168 (747)	84 (374)	0.30 (7.6)
5	1-3/4 (44.5)	8, 10, 12 & 14 (203, 254, 305 & 356)	55 (16.8)	3,000 (4,100)	240* (1068)*	120 (534)	0.20 (5.1)
6	1-3/4 (44.5)	8, 10, 12 & 14 (203, 254, 305 & 356)	25 (7.6)	2,000 (2,700)	180* (801)*	90 (400)	0.25 (6.4)
7	1-3/4 (44.5)	6, 8, 10 & 12 (152, 203, 254 & 305)	25 (7.6)	3,000 (4,100)	132 (587)	66 (294)	0.30 (7.6)
8	1-3/4 (44.5)	6, 8, 10 & 12 (152, 203, 254 & 305)	30 (9.1)	2,000 (2,700)	152 (676)	76 (338)	0.30 (7.6)

\* Ultimate Capacity has been extrapolated.

Figure 8 – Summary of Load Tests

for Test Pile #3. It demonstrates how capacity, working load and deflection at working load were determined for each performance test. Figure 8 is a summary of all 8 load tests.

The Figure 9 graph was used as a field installation guideline to determine the total depth of installation required. The diamond points represent a specific load test while each dotted line then represents a pile depth. As an example, with a required working load of 80 kip, installation could stop if the helical pile was 15-feet in depth and the installation torque exceeded 9,500 ft-lb. If the torque was below 9,500 ft-lb, the helical pile had to be installed deeper. At a depth of 20-feet, a minimum torque of 6,500 ft-lb was required. At 25-feet, a minimum torque of 4,000 ft-lb was required. And finally, at 30-feet, a minimum torque of 2,800 ft-lb was required.

### Performance Test Discussion

The graph in Figure 9 worked well as a field tool. In essence, a deeper pile generated more capacity from friction along the grout column-soil interface. A shallower pile required more installation torque and hence more end-bearing capacity was generated. Figure 8 demonstrates that the longer piles, generating more frictional capacity, deflected less at the working

load than the shorter piles. The shorter piles responded like typical end-bearing piles requiring more displacement to generate capacity. This agrees with Figure 5 referenced earlier.

Tasker HPM - Torque vs Working Load

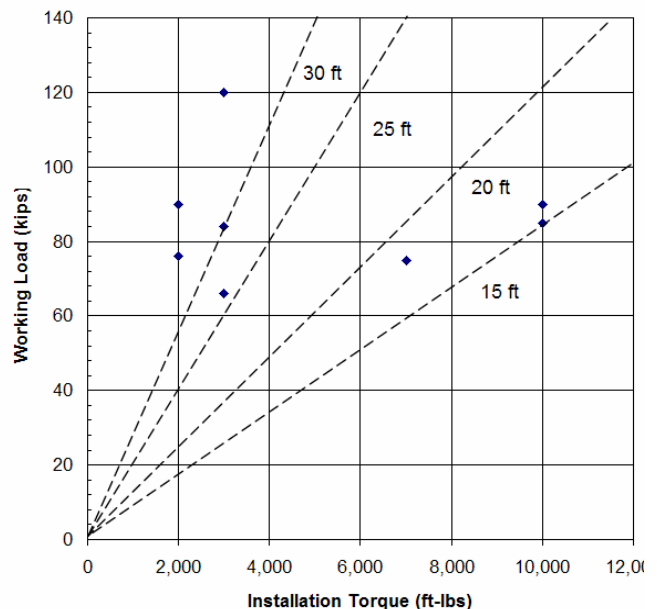

Figure 9 – Torque and Depth vs. Working Load

### Installation Equipment

Phase I was installed with a single installing unit consisting of a 12,000 ft-lb Eskridge torque motor mounted on the boom of a 312 Caterpillar excavator. The grout was mixed with an onsite batch plant and transport in a hopper. Phase II was installed with two installing units, both consisting of a 17,000 ft-lb Eskridge torque motor mounted on the boom of a 312 Caterpillar excavator, see Figure 10. Grout was supplied with a ready-mix truck for Phase II.



Figure 10  
Phase II & III Excavator and Torque Motor

### Foundation Construction Sequence

The site was stripped of vegetation, top soil, etc. Existing buildings were demolished and suitable material used on the site as fill. The entire site was graded to the structural slab elevation. Grouted helical piles were installed to the ground surface. A trench for the grade beam was excavated around the helical piles before the piles were cut to the required elevation. A new construction bracket was installed on top of the helical pile and the rebar cage constructed. The grade beam forms were erected and the grade beam poured. After the forms were removed, the trench was backfilled in preparation to form and pour the structural slab.

### Installation Discussion

Phase I required 1600 piles and was installed over 6 months from April to October 2003 with 1 excavator and 2 mobilizations/demobilizations. Phase II and III combined required 2045 piles and were installed from March to November 2004 with 2 excavators and 3 mobilizations/demobilizations.

Installation depths varied from 15 to 50-feet across the site with the majority falling between 20 to 30-feet. The rate of installation varied from 20 to 60 piles for each excavator during an 8 hour shift. The production rate depended on the soil encountered and the depth

of installation. If the soil was unusually difficult, a 6-inch auger was used to pre-drill the first 10-feet.

Tolerance on pile location was  $\pm$  3-inches perpendicular to the grade beam direction and  $\pm$  12-inches inline with the grade beam. Of the 3645 piles installed, 14 (0.4%) were installed 0 to 3-inches out of tolerance (or 3 to 6-inches from dead center). To remedy this condition, the grade beam was widened at that location. No piles were installed more than 3-inches out of tolerance.

### Acknowledgement

The authors would like to note that the helical pile with grouted shaft, both method and apparatus, is patented.

### References

- A. B. Chance Company, *Helical Screw Foundation – Design Manual for New Construction*, Copyright 2003  
A. B Chance Company, 210 North Allen St., Centralia, MO 65240.
- Downey, S. and Brown, A., 2003, “Helical Piles With Grouted Shafts – A Case History”, Deep Foundation Institute, 28<sup>th</sup> Annual Conference On Deep Foundations, Miami Beach, Florida
- Harpstead, D.L. and Morrison, J., 2002, “Proposed Construction – Sequence I, Philadelphia Housing Authority, Tasker Homes, Philadelphia, PA”, Geotechnical Engineering Evaluation, Powell-Harpstead, Inc.
- Hoyt, R.M. and Clemence, S.P., 1989, “Uplift Capacity of Helical Anchors in Soil”, Proc. 12<sup>th</sup> International Conference on Soil Mechanics and Foundation Engineering, Rio de Janeiro, Brazil.
- Reese, L.C. and Wright, S.J., 1977, “Drilled Shaft Design and Construction Guidelines Manual”, U.S. Department of Transportation, Federal Highway Administration
- Seider, G.L., Clemence, S.P. and Thorsten, R.E., (2003), “Helical Piles with Grouted Shafts – A Practical Overview”, Proceedings of the DFI 28<sup>th</sup> Annual Conference on Deep Foundations, Miami Beach, FL.
- Terzaghi, K. and Peck, R.B., 1948 “Soil Mechanics in Engineering Practice”, John Wiley and Sons.
- United States Patent 5,707,180, Method and Apparatus for Forming Piles In-Situ, Vickars, R.A., Vickars, J.C.T., Toebosch, G.
- Vickars, R.A. and Clemence, S.P., 2000, “Performance of Helical Piles with Grouted Shafts”, Proc. New Technological and Design Developments in Deep Foundations, ASCE GSP 100, Denver CO.
- HELICAL PULLDOWN® Micropile is a registered trademark of Hubbell Power Systems, Inc./CHANCE Civil Construction.